

POWER RELAY

2 POLES - 8A Low Profile Type

FTR-F1 R Series

■ FEATURES

- DPST/DPDT 8A
 - Low profile power relay (height 16.5 mm) employing unique construction
 - High insulation by employing reinforced insulation construction
Insulation distance: 8 mm (between coil and contact)
Dielectric strength: 5 kV (between coil and contact)
Surge strength: 10 kV (between coil and contact)
 - UL, CSA, VDE recognized
 - Flux proof sealing, RTII
 - RoHS Compliant
- Please see page 6 for more information



■ PARTNUMBER INFORMATION

[Example] FTR-F1 A L 005 R - RG
 (a) (b) (c) (d) (e) (f)

(a)	Relay type	FTR-F1	: FTR-F1-Series
(b)	Contact configuration	A C	: 2 form A (SPST-NO) : 2 form C (DPDT)
(c)	Coil type / enclosure	A L	: Standard type (530mW) : High sensitive type (400mW)
(d)	Coil rated voltage	005	: 1.5...110VDC (High sensitive type: 1.5...48V) Coil rating table at page 3
(e)	Contact rating	R	: 8A
(f)	Special type	Nil RG	: Standard type : Transparent cover type

Actual marking does not carry the type name : "FTR"
 E.g.: Ordering code: FTR-F1AL005R Actual marking: F1AL005R

FTR-F1 SERIES

■ SPECIFICATION

Item			Standard type F1 (A, C) L () R	Transparent cover F1 (A, C) L () R - RG
Contact Data	Configuration		2 form A (DPST-NO), 2 form C (DPDT)	
	Construction		Single	
	Material		Movable: Gold plate silver tin oxide; Stationary: Silver tin oxide	
	Resistance (initial)		Max. 100mΩ at 1A, 6VDC	
	Contact rating		8A, 250VAC / 24VDC	
	Max. carrying current * ¹		8A	
	Max. switching voltage		400VAC/ 300VDC	
	Max. switching power		2,000VA, 192W	
	Min. switching load * ²		10mA, 5VDC	
Life	Mechanical		Min. 20x 10 ⁶ operations	
	Electrical	AC load	Min. 50 x 10 ³ operations	
		DC load	Min. 50 x 10 ³ operations	
Coil Data	Rated Power (at 20 °C)		Standard type: 530~550mW /High sensitive type: 400mW	
	Operate Power (at 20 °C)		Standard type: 260~270mW /High sensitive type: 225mW	
	Operating temperature range		-40 to +75 °C (no frost)	-40 to +70 °C (no frost)
Timing Data	Operate (at nominal voltage)		Max. 15ms (no diode, without bounce)	
	Release (at nominal voltage)		Max. 5ms (no diode, without bounce)	
Insulation	Resistance (Initial)		Min. 1,000MΩ at 500VDC	
	Dielectric strength	Open contacts	1,000VAC (50/60Hz) 1min.	
		Coil and contacts	5,000VAC (50/60Hz) 1min.	
		Adjacent contacts	3,000VAC (50/60Hz) 1 min.	
	Surge strength	Coil and contacts	10.000V/ 1.2 x 50μs standard wave	
	Clearance		8 mm	
	Creepage		8 mm	
	EN61810-1, VDE0435	Voltage	250V	
		Pollution degree	3	
		Material group	IIIa	
	Category	C / 250V (reference voltage) (VDE0110b)		
Other	Vibration Resistance	Misoperation	10 to 55 to 10 Hz single amplitude 0.825mm	
		Endurance	10 to 55 to 10 Hz single amplitude 1.65mm	
	Shock	Misoperation	Min. 100 m/s ² (11 ± 1ms)	
		Endurance	Min. 1,000 m/s ² (6 ± 1ms)	
	Weight		Approximately 12 g	
	Sealing		Flux proof, RTII	

* Minimum switching loads mentioned above are reference values. Please perform the confirmation test with actual load before production since reference values may vary according to switching frequencies, environmental conditions and expected reliability levels.

■ COIL RATING

530mW type (Standard)

Coil Code	Rated Coil Voltage (VDC)	Coil Resistance +/- 10% (Ohm)	Must Operate Voltage (VDC) *	Must Release Voltage (VDC) *	Rated Power (mW)
1.5	1.5	4.2	1.05	0.15	530
005	5	47	3.5	0.5	
006	6	68	4.2	0.6	
009	9	155	6.3	0.9	
012	12	270	8.4	1.2	
024	24	1,100	16.8	2.4	
048	48	4,400	33.6	4.8	
060	60	6,800	42.0	6.0	550
110	110	22,000	77.0	11.0	

400mW type (High sensitive)

Coil Code	Rated Coil Voltage (VDC)	Coil Resistance +/- 10% (Ohm)	Must Operate Voltage (VDC) *	Must Release Voltage (VDC) *	Rated Power (mW)
1.5	1.5	5.6	1.125	0.15	400
003	3	22.5	2.25	0.3	
005	5	62	3.75	0.5	
006	6	90	4.5	0.6	
009	9	202	6.75	0.9	
012	12	360	9	1.2	
024	24	1,440	18	2.4	
048	48	5,760	36	4.8	

Note 1: All values given in the coil table(s) are valid at 20°C ambient temperature, at zero contact current, without pre-energizing and * are specified at pulse wave voltage.

Note 2: When applying a higher than rated coil voltage, please refer to the "coil temperature rise" and "operating range". Reference graphs for the effects on the relay operating behaviour.

■ SAFETY STANDARDS

Type	Compliance	Contact rating
UL	UL 508 (No. E63614)	Flammability: UL 94-V0 (plastics) 8A, 24VDC (resistive) 8A, 250VAC (resistive)
CSA	C22.2 No. 14 (No. LR40304)	1/6 hp, 125VAC 1/4 hp, 250VAC Pilot duty: C300, R300 except -RG
VDE	IEC/EN61810-1 EN60335-1 clause 15.3; 16.3; 29.1; 29.2; 29.3 EN60730-1 clause 12.2; 13.2; 20.1; 20.2; 20.3	8A, 250 VAC (cosφ=1) 8A, 24VDC (0ms)

CHARACTERISTIC DATA (Reference)

* Characteristic data is not a guaranteed value, but measured values of samples from production line.

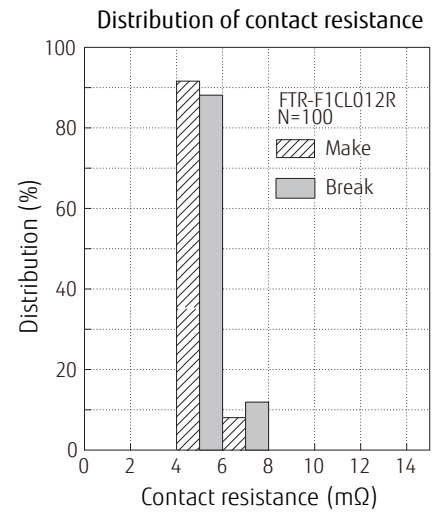
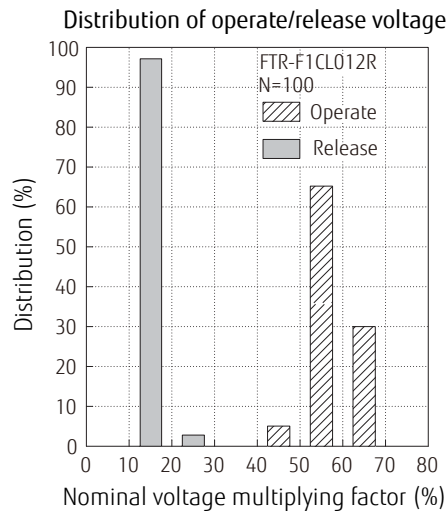
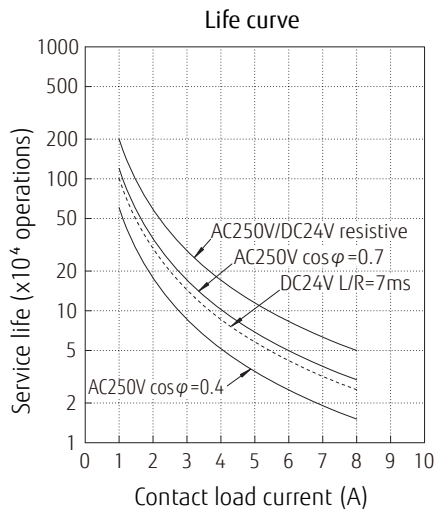
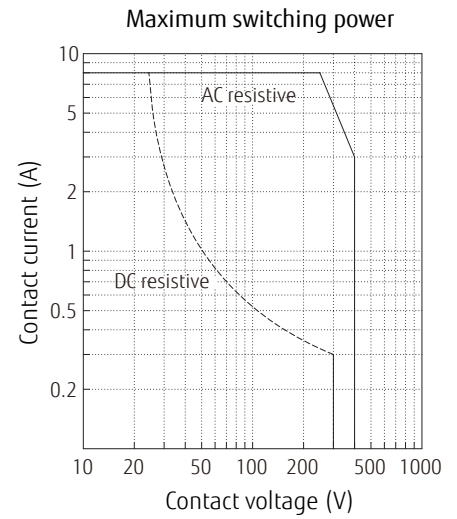
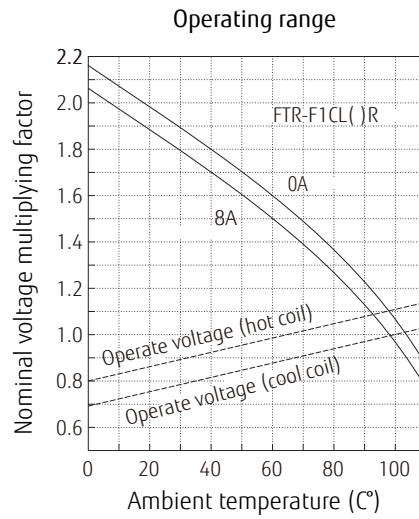
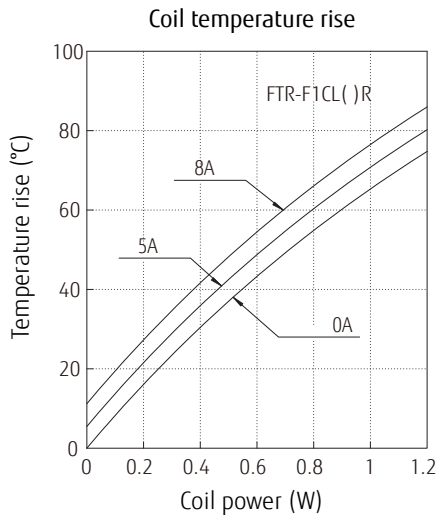

■ DIMENSIONS

FTR-F1A type

● Dimensions

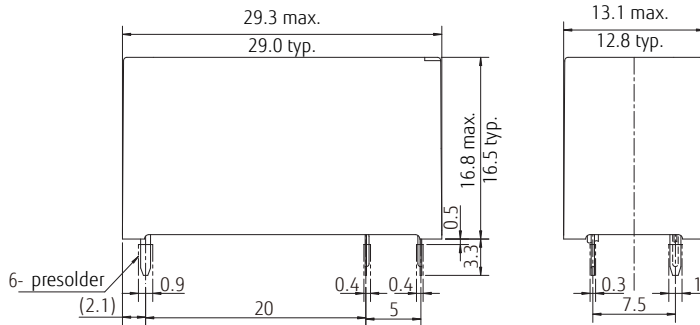

● Schematics (BOTTOM VIEW)

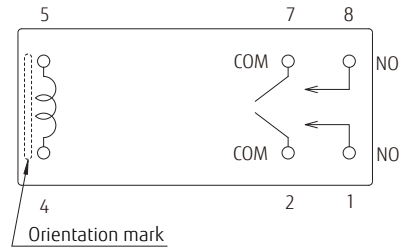

● PC board mounting hole layout (BOTTOM VIEW)

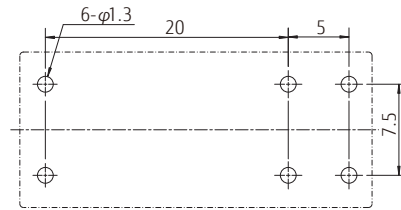

FTR-F1C type

● Dimensions

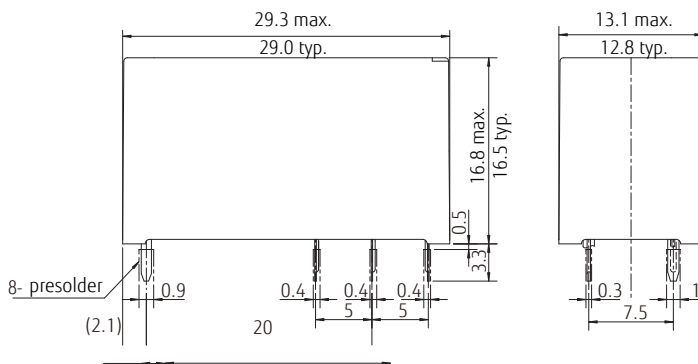

● Schematics (BOTTOM VIEW)

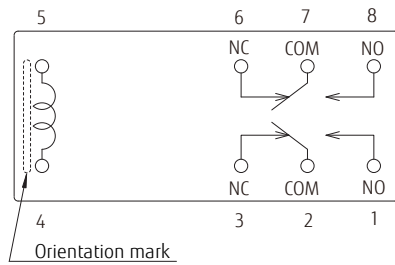

● PC board mounting hole layout (BOTTOM VIEW)

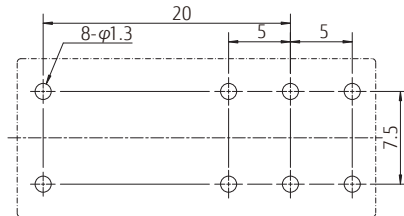

- * Dimensions of the terminals do not include thickness of pre-solder.
- * Tolerance of PC board mounting hole layout : ± 0.1 unless otherwise specified.

Unit: mm
(): Reference

Cautions

- All values mentioned in this datasheet are provided under ideal conditions. Please perform the confirmation test before actual use.
- Reflow soldering is prohibited.
- Do not use relays in the atmosphere with sulfide gas, chloride gas or nitric oxide. Contact resistance may increase.
- Do not use silicon or silicon-containing product or materials near relays. It may cause contact failure.

RoHS Compliance and Lead Free Information

1. General Information

- All relays produced by Fujitsu Components are compliant with RoHS directive 2011/65/EU including amendments.
- Cadmium as used in electrical contacts is exempted from the RoHS directives. As per Annex III of directive 2011/65/EU.
- All relays are lead-free. Please refer to Lead-Free Status Info for older date codes at: <http://www.fujitsu.com/downloads/MICRO/fcai/relays/lead-free-letter.pdf>
- Lead free solder plating on relay terminals is Sn-3.0Ag-0.5Cu, unless otherwise specified. This material has been verified to be compatible with PbSn assembly process.

2. Recommended Lead Free Solder Condition

- Recommended solder Sn-3.0Ag-0.5Cu.

Flow Solder Condition:

Pre-heating: maximum 120°C
within 90 sec.
Soldering: dip within 5 sec. at
255°C ± 5°C solder bath
Relay must be cooled by air immediately
after soldering

Solder by Soldering Iron:

Soldering Iron 30-60W
Temperature: maximum 350-360°C
Duration: maximum 3 sec.

We highly recommend that you confirm your actual solder conditions

3. Moisture Sensitivity

- Moisture Sensitivity Level standard is not applicable to electromechanical relays, unless otherwise indicated.

4. Tin Whiskers

- Dipped SnAgCu solder is known as presenting a low risk to tin whisker development. No considerable length whisker was found by our in house test.

Fujitsu Components International Headquarter Offices

Japan FUJITSU COMPONENT LIMITED Shinagawa Seaside Park Tower 19F, 12-4, Higashi-shinagawa 4-chome, Shinagawa-ku, Tokyo, 140-0002, Japan Tel: (81-3) 3450-1682 Fax: (81-3) 3474-2385 Email: fcl-contact@cs.jp.fujitsu.com Web: www.fujitsu.com/jp/fcl/	Asia Pacific FUJITSU COMPONENTS ASIA, LTD. 102E Pasir Panjang Road #01-01 Citilink Warehouse Complex Singapore 118529 Tel: (65) 6375-8560 Fax: (65) 6273-3021 Email: fcal@sg.fujitsu.com Web: www.fujitsu.com/sg/products/devices/components	Korea FUJITSU COMPONENTS KOREA LIMITED Alpha Tower #403, 645 Sampoong-dong, Bundang-gu, Seongnam-si, Gyeonggi-do, 13524 Korea Tel: (82) 31-708-7108 Fax: (82) 31-709-7108 Email: fcal@sg.fujitsu.com www.fujitsu.com/sg/products/devices/components/
North and South America FUJITSU COMPONENTS AMERICA, INC 2290 North First Street, Suite 212 San Jose, CA 95131, USA Tel: (1-408) 745-4900 Fax: (1-408) 745-4970 Email: components@us.fujitsu.com Web: us.fujitsu.com/components	China FUJITSU ELECTRONIC COMPONENTS (SHANGHAI) CO., LTD. Unit 4306, InterContinental Center 100 Yu Tong Road, Shanghai 200070, China Tel: (86-21) 3253 0998 Fax: (86-21) 3253 0997 Email: fclsh@cn.fujitsu.com Web: www.fujitsu.com/cn/products/devices/components	
Europe FUJITSU COMPONENTS EUROPE B.V. Diamantlaan 25 2132 WV Hoofddorp Netherlands Tel: (31-23) 5560910 Fax: (31-23) 5560950 Email: info@fceu.fujitsu.com Web: www.fujitsu.com/uk/components	Hong Kong FUJITSU COMPONENTS HONG KONG CO., LTD Unit 506, Inter-Continental Plaza No.94 Granville Road, Tsim Sha Tsui, Kowloon, Hong Kong Tel: (852) 2881-8495 Tex: (852) 2894-9512 Email: fcal@sg.fujitsu.com Web: www.fujitsu.com/sg/products/devices/components/	

©2019 Fujitsu Components Europe B.V. All rights reserved. All trademarks or registered trademarks are the property of their respective owners.

The contents, data and information in this datasheet are provided by Fujitsu Component Ltd. as a service only to its user and only for general information purposes.

The use of the contents, data and information provided in this datasheet is at the users' own risk.

Fujitsu has assembled this datasheet with care and will endeavor to keep the contents, data and information correct, accurate, comprehensive, complete and up to date.

Fujitsu Components Europe B.V. and affiliated companies do however not accept any responsibility or liability on their behalf, nor on behalf of its employees, for any loss or damage, direct, indirect or consequential, with respect to this datasheet, its contents, data, and information and related graphics and the correctness, reliability, accuracy, comprehensiveness, usefulness, availability and completeness thereof.

Nor do Fujitsu Components Europe B.V. and affiliated companies accept on their behalf, nor on behalf of its employees, any responsibility or liability for any representation or warrant of any kind, express or implied, including warranties of any kind for merchantability or fitness for particular use, with respect to these datasheets, its contents, data, information and related graphics and the correctness, reliability, accuracy, comprehensiveness, usefulness, availability and completeness thereof. Rev. July 26th, 2019